

FEATURES

- Low profile
- Wide frequency range
- Extended temperature range
- High stability
- Built-in load capacitance

CERAMIC RESONATOR

The ZTT Series ceramic resonator offers wide frequency range and extended temperature range capabilities with built-in load capacitance.

OPERATING CONDITIONS/ELECTRICAL CHARACTERISTICS

PART NUMBER *	FREQUENCY RANGE (MHz)	FREQUENCY ACCURACY @ 25° (%)	STABILITY IN TEMPERATURE -20° ~ 80° C (%)	AGING FOR TEN YEARS (%)	RESONANT RESISTANCE (Ω) MAX.	WITHSTANDING VOLTAGE (5 SEC. MAX.)	INSULATION RESISTANCE (Ω)
ZTT□.□□MG	2.00 ~ 2.99	±0.5	±0.3	±0.3	80	100 V DC	5X10 ⁸ Min. @ 10 V DC
ZTT□.□□MG	3.00 ~ 3.49	±0.5	±0.3	±0.3	50	100 V DC	5X10 ⁸ Min. @ 10 V DC
ZTT□.□□MG	3.50 ~ 4.99	±0.5	±0.3	±0.3	30	100 V DC	5X10 ⁸ Min. @ 10 V DC
ZTT□.□□MT	5.00 ~ 6.99	±0.5	±0.3	±0.3	30	100 V DC	5X10 ⁸ Min. @ 10 V DC
ZTT□.□□MT	7.00 ~ 13.00	±0.5	±0.3	±0.3	25	100 V DC	5X10 ⁸ Min. @ 10 V DC
ZTT□.□□MX	13.01 ~ 48.00	±0.5	±0.3	±0.3	55	100 V DC	5X10 ⁸ Min. @ 10 V DC

* Complete part number to include frequency i.e. ZTT10.00MT (10.00 = 10.00 MHz)

PACKAGE DIMENSIONS (mm)

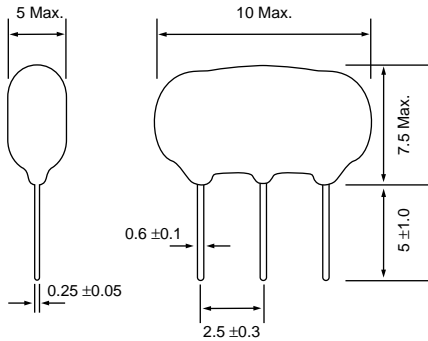

Figure 1) ZTT □.□□MG, Front and Side views

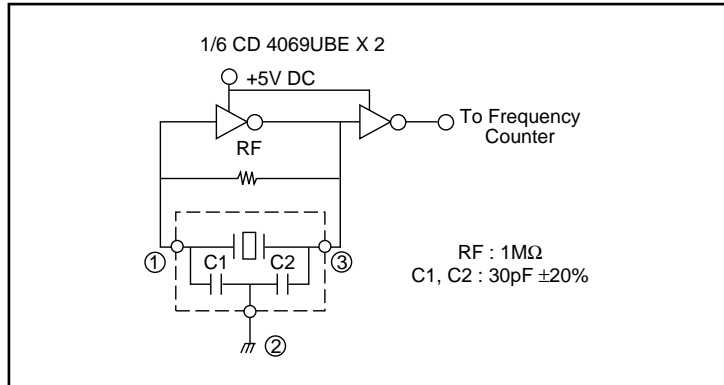

Figure 2) ZTT □.□□MG Test Circuit

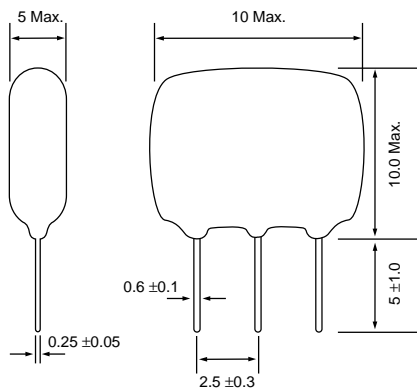

Figure 3) ZTT □.□□MT, MX Front and Side views

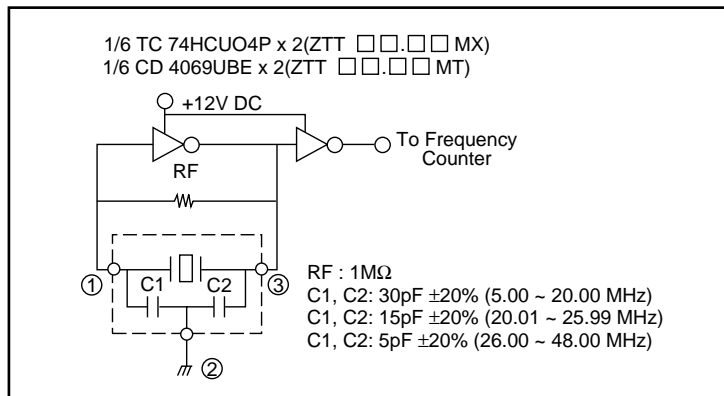

Figure 4) ZTT □.□□MT & ZTT □.□□MX Test Circuit